

GENERAL DESCRIPTION

EK-WL8-HS is a combined wireless A1R heat sensor and sounder.

The sensor analyses the environmental temperature in the protected area. An alarm condition is generated when the temperature level or the temperature rise exceeds the threshold. The alarm signal is relayed to the Control Panel via the connected translator/expander modules.

The thermal sensor is A1R type.

The device is supplied with a mounting kit.

The product complies with the requirements of the AS ISO 7240.5 and AS ISO 7240.25 standards.



FEATURES

- A1R classified
- Bi-directional wireless communication
- Intelligent algorithms
- Integrated sounder
- Tamper switch
- 10-year battery life
- Self-optimizing wireless frequency and amplitude algorithms

GENERAL OVERVIEW

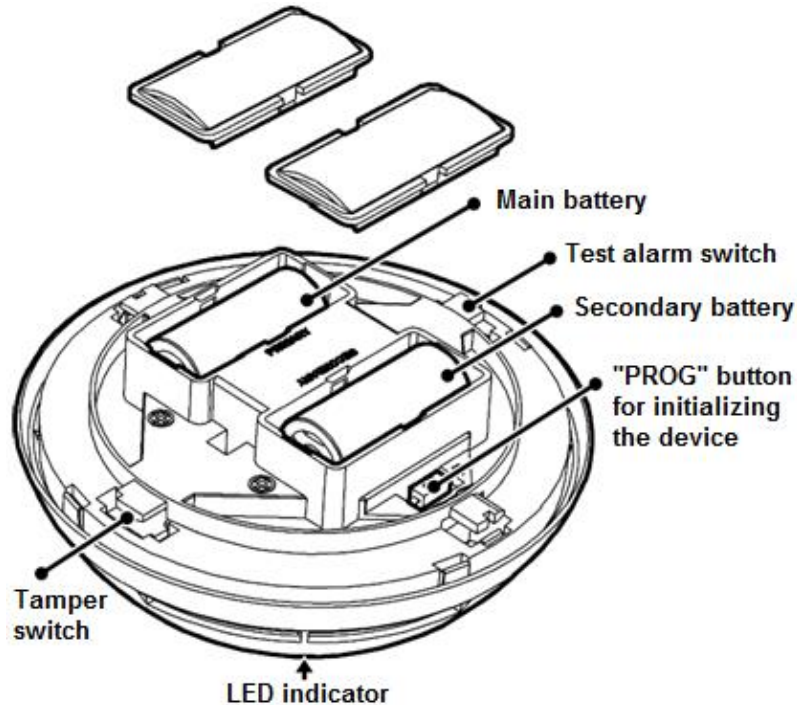

TECHNICAL SPECIFICATIONS

Communication range with a translator or expander	1200 m
Radio frequency	918-926 MHz
Modulation type	GFSK
Operating frequency channels	6
Radiated power	Not more than 25 mW
Receiver category (EN300-220-1)	1.5
Sound pressure level at 1 m	> 96 dB(A) for all modes*
Battery life:	
Primary battery (type CR123A, 2.75-3.2V)	> 8-10 years
Secondary battery (type CR123A, 2.75-3.2V)	> 3 months (after primary battery low fault)
Dimensions (with the base)	111 mm x 76 mm
Weight	200 g
Max tolerated humidity	95% RH
Operating temperature range	From -10 °C to +55 °C

*see full table at the end of the document

NOTE Check the latest version of the product specification document STFV.425238.038-E-PS for further data, obtainable from the manufacturer.

PROGRAMMING

The “Prog.” button on the device is used for initializing the device on to the system. Please refer to the translator manual for full instructions on how to add a device to the system. The device can also be initialized using the “Ekho Configuration” software.

INSTALLATION

In order to install the device, the mounting base should be fixed to the ceiling, the sensor can then be inserted into the base by rotating the sensor until it clips into the base.

Preferably, the device should be installed away from metallic objects, doors, and power lines, as they can cause the communication distance to drop. It is also important to avoid installing the device near electronics and computer equipment in order to protect them from potential electromagnetic interference.

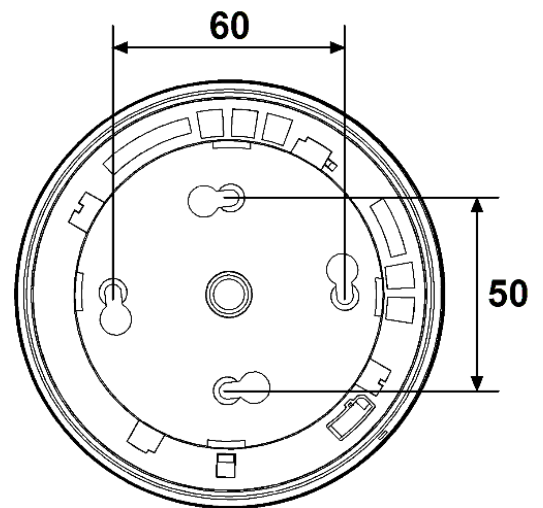

INDICATION

The device has an LED which indicates its state according to the following:

LED indication	Device's state
No indication or green flashes	Standby mode
Yellow flashes every 4 seconds	Fault state – low battery or thermal sensor fault
Red flashes every 2 seconds	Fire alarm
Frequent red flickering	Sounder is activated

TESTING

An alarm test can be performed with a magnet by placing it onto the outside of the sensor (opposite side to the base alignment marks) the sensor should take around 1 second to activate.

A suitable heat test tool can also be used, please follow the instructions to apply heat to the sensor in the correct way.

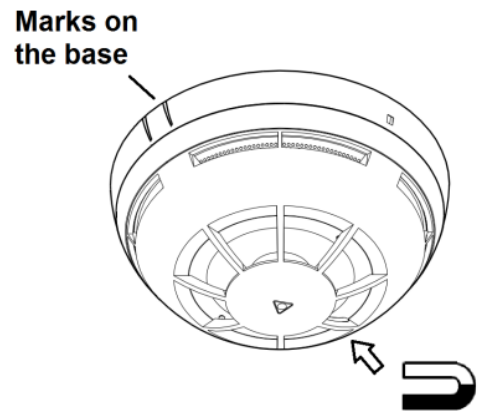

ANALOG DATA

The device provides the translator module with analog data about the current air temperature and voltage levels of its batteries. This information can be viewed in the “Ekho Configuration” software.

Sensor	Partition	Primary supply	Standby supply	Temperature
3 WL8-HS	003: Partition	3.1 V	3.3 V	25 °C

By analyzing the voltage levels, you can manage your maintenance procedures and predict when you will have to replace the batteries. Please refer to the software manual for full instructions on how to use the program for system maintenance.

SOUNDER

The **EK-WL8-HS** sounder can produce two frequencies:

Tone Mode	Frequency
Tone1	3500 Hz
Tone2	2150 Hz

The device has six selectable tones, these can be selected via the EK-WL8-TRH translator menu.

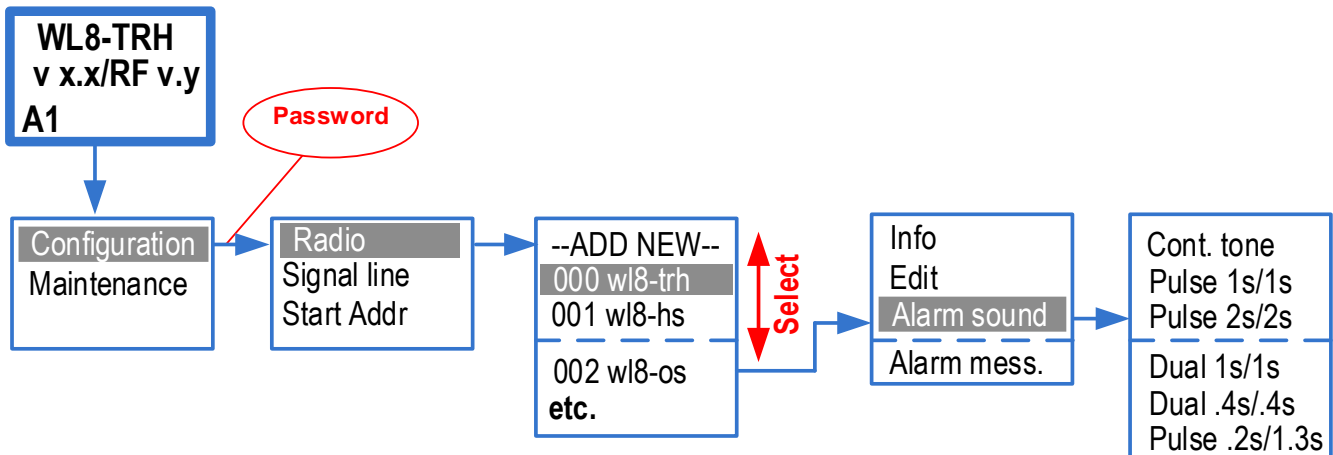

Sound Alert Mode	Tone	Duty cycle
One-tone Continuous	Tone1	On
One-tone intermittent	Tone1	1s On / 1s Off
One-tone intermittent	Tone1	2s On / 2s Off
Two-tone	Tone1 & Tone2	1s / 1s
Two-tone	Tone1 & Tone2	0,4s / 0,4s
One-tone intermittent	Tone1	0,2s On / 1,3s Off

WARNINGS & LIMITATIONS

Devices use high quality electronic components and plastic materials that are highly resistant to environmental deterioration. However, after 10 years continuous operation it is advisable to replace them to reduce the risk of reduced performance caused by external factors. Ensure the devices are only used with compatible control panels. Detection systems must be checked, serviced and maintained on a regular basis to confirm correct operation.

Refer to and follow National Codes of Practice and other internationally recognized fire engineering standards. Appropriate Risk Assessment should be carried out initially to determine correct design criteria and updated periodically.

WARRANTY

All devices are covered by a 3 year limited warranty (does not apply to batteries). The warranty is voided by mechanical or electrical damage caused by incorrect handling or usage. Product must be returned via an authorized supplier for repair or replacement along with full information on the identified problem.

	EK-WL8-HS/AU WIRELESS HEAT SENSOR WITH BUILD-IN SOUNDER	
STFV.425238.038-AU-UM rev. 19	06.11.2020	Page 6 from 8

BATTERY REPLACEMENT

When a battery requires replacement, both batteries must be changed together.

- a. Remove the sensor from the base.
- b. Clip off the battery cover and remove the batteries.
- c. Insert the new batteries as detailed in the installation manual above – take care to observe + / - polarity.
- d. Re-fit the battery cover and re-insert the sensor into the base.
- e. Test the sensor in accordance with the manufacturer's instructions.

It is recommended to change both batteries after 10 years of operation regardless of their indicated discharge level.

To replace the batteries, use Panasonic CR123A (primary and secondary batteries) or other with similar characteristics. The batteries must meet the following standards: UL 1642 lithium batteries, UL certified at www.ul.com or IEC 60086-4 Primary batteries, Part 4: Safety of lithium batteries. The remaining shelf time of the new batteries must be not less than 8 years.

Failure to observe these instructions will void the device warranty and any liabilities.

CAUTION

- Replacement of a batteries must be of the same type.
- Do not expose used batteries to fire, hot ovens, or mechanical crushing/cutting as this can result in an explosion.
- Exposing batteries to extremely high environmental temperatures can result in explosion or the leakage of flammable liquid or gas.
- A battery subjected to extremely low air pressure may result in an explosion or the leakage of flammable liquid or gas.

DISPOSAL

- Follow local regulations regarding disposal of the batteries

Angle	Minimal sound pressure level, dB(A) for all supply voltages at 1 m
	Horizontal and vertical plane
15°	88.4
45°	94.2
75°	97.6
105°	97.9
135°	94.3
165°	85

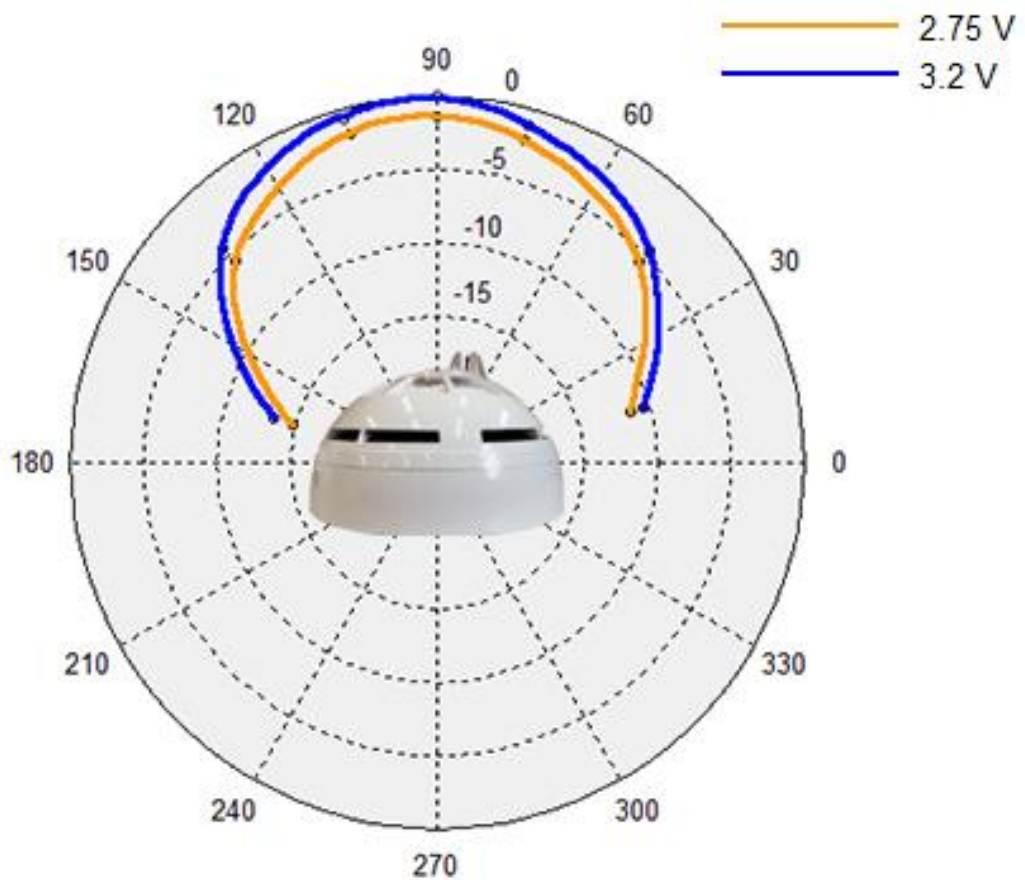



**EK-WL8-HS/AU
WIRELESS HEAT SENSOR
WITH BUILD-IN SOUNDER**

STFV.425238.038-AU-UM rev. 19

06.11.2020

Page 8 from 8



**Australian
Standard**

SAI Global

Lic SMK 41078



ABN No

67 153 750 648

Hochiki Australia Pty Ltd

Block Y, Unit 1 Regents Park Estate
391 Park Rd, Regents Park
NSW 2143, Australia

Telephone: +61 2 9738 5566

Web: www.hochikiaustralia.com

Email: sales@hochikiaustralia.com